



SAT-201 User Manual

Document No: MAN-0019

Issue No: 2

Dated: 16 June 2005



COPYRIGHT

Copyright in this document is vested in Satamatics Ltd. This document is issued in confidence for the purpose only for which it is supplied. It must not be reproduced in whole or in part except with the consent in writing of Satamatics Ltd and then only on the condition that this notice is included in any such reproduction.

Revision History

Date	Issue	Comments
19 April 2005	1	Initial Issue.
16 June 2005	2	3.1 Minor changes to European Compliance Statement 11.3 Included warning regarding IO devices default state 14. Minor Change to Product Information

CONTENTS

1	LEGAL INFORMATION.....	4
1.1	Notice	4
1.2	Limited Warranty	4
1.3	Limitation of Warranty	4
1.4	Governing Law	4
2	SAFETY WARNINGS	5
2.1	General Safety Warnings	5
3	REGULATORY AND TYPE APPROVAL INFORMATION.....	6
3.1	European Compliance	6
3.2	FCC Authorisation.....	6
3.3	INMARSAT Type Approval	6
3.4	Limitations on intended operating environment.....	6
4	SAT-201 GENERAL DESCRIPTION	7
5	INSTALLATION.....	8
5.1	Power Requirements	8
5.2	Cable.....	8
5.3	Location.....	9
5.4	Mounting	10
5.5	Applying Power	12
5.6	Operational Check	12
6	FUNCTIONALITY	13
7	MODES OF OPERATION.....	13
8	FACTORY DEFAULTS.....	13
9	MAINTENANCE AND SUPPORT INFORMATION.....	14
9.1	Cleaning	14
9.2	Technical Support and Information	14
10	SPECIFICATIONS	15
11	INTERFACES	17
11.1	Interface Connector Pinout.....	17
11.2	Interface functions.....	17
11.3	General Purpose I/O.....	18
12	INTERPRETING THE INDICATOR	19
13	APPENDIX – A	20
13.1	CE Declaration of Conformity	20
14	Product Information.....	21

1 LEGAL INFORMATION

1.1 Notice

Information in this document is subject to change without notice. Satamatics Ltd. makes no warranty of any kind with regards to this material, including, but not limited to, the implied warranties of merchantability and fitness for purpose. Satamatics Ltd. shall not be liable for errors contained herein or for incidental or consequential damages in connection with the use of this material. No part of this document may be photocopied, reproduced, or translated to another language without prior written consent of Satamatics Ltd. The Satamatics logo is a registered trademark of Satamatics Ltd. All other trademarks belong to their respective proprietors.

1.2 Limited Warranty

Satamatics warrants that the SAT-201 product will be free from defects in material and workmanship for a period of one (1) year from date of purchase. During the warranty period Satamatics Ltd will, at its option, either repair or replace products that prove to be defective. If a defect exists, at its option Satamatics Ltd will repair the product at no charge, using new or refurbished replacement parts, or exchange the product with a product that is new or which has been manufactured from new or serviceable used parts and is at least functionally equivalent to the original product. A replacement product assumes the remaining warranty of the original product or 90 days, whichever is the longer for you. All Hardware (or part thereof) that is replaced by Satamatics Ltd shall become the property of Satamatics Ltd upon replacement. Satamatics does not warrant that the operation of the equipment or firmware will be uninterrupted or error free.

For warranty service or repair the product must be returned to a service facility designated by Satamatics Ltd quoting the information contained in Section 14. Failure to do so could invalidate or delay any warranty repair.

1.3 Limitation of Warranty

The foregoing warranty shall not apply to defects resulting from improper or inadequate maintenance by the Buyer, Buyer-supplied software (scripts) or interfacing, unauthorized modification or misuse, operation outside of the environmental specifications for the product, or improper installation.

EXCEPT FOR THE ONE (1) YEAR LIMITED WARRANTY SPECIFIED HEREIN, THE PRODUCT IS PROVIDED "AS-IS" WITHOUT ANY WARRANTY OF ANY KIND INCLUDING, WITHOUT LIMITATION, ANY WARRANTY OF MERCHANTABILITY, FITNESS FOR A PARTICULAR PURPOSE AND NON-INFRINGEMENT. If ANY IMPLIED WARRANTY CANNOT BE DISCLAIMED IN ANY TERRITORY WHERE A PRODUCT IS SOLD, THE DURATION OF SUCH IMPLIED WARRANTY SHALL BE LIMITED TO NINETY (90) DAYS. EXCEPT AS EXPRESSLY COVERED UNDER THE LIMITED WARRANTY PROVIDED HEREIN, THE ENTIRE RISK AS TO THE QUALITY, SELECTION AND PERFORMANCE OF THE PRODUCT IS WITH THE PURCHASER OF THE PRODUCT.

TO THE MAXIMUM EXTENT PERMITTED BY LAW, SATAMATICS LTD IS NOT LIABLE UNDER ANY CONTRACT, NEGLIGENCE, STRICT LIABILITY OR OTHER LEGAL OR EQUITABLE THEORY FOR ANY LOSS OF USE OF THE PRODUCT, INCONVENIENCE OR DAMAGES OF ANY CHARACTER, WHETHER DIRECT, SPECIAL, INCIDENTAL OR CONSEQUENTIAL (INCLUDING, BUT NOT LIMITED TO, DAMAGES FOR LOSS OF GOODWILL, WORK STOPPAGE, COMPUTER FAILURE OR MALFUNCTION, LOSS OF INFORMATION OR DATA CONTAINED IN, STORED ON, OR INTEGRATED WITH ANY PRODUCT RETURNED TO SATAMATICS LTD FOR WARRANTY REPAIR) RESULTING FROM THE USE OF THE PRODUCT, RELATING TO WARRANTY SERVICE, OR ARISING OUT OF ANY BREACH OF THIS LIMITED WARRANTY, EVEN IF SATAMATICS LTD HAS BEEN ADVISED OF THE POSSIBILITY OF SUCH DAMAGES. THE SOLE REMEDY FOR A BREACH OF THE FOREGOING LIMITED WARRANTY IS REPAIR OR REPLACEMENT OF THE DEFECTIVE OR NON-CONFORMING PRODUCT.

1.4 Governing Law

The laws of England and Wales shall govern this one (1) year warranty. Some countries do not allow the exclusion or limitation of incidental or consequential damages or exclusions or limitations on the duration of implied warranties or conditions. The above limitations may not therefore apply to you. This warranty gives you specific legal rights, and you may also have rights that vary by country.

2 SAFETY WARNINGS



BEFORE APPLYING POWER TO THE EQUIPMENT the user must read all instructions. If in any doubt, consult suitably trained service personnel.

2.1 General Safety Warnings

- No user serviceable parts inside. Refer servicing to qualified service personnel.
- The equipment contains no replaceable fuses.
- Retain the safety and operating instructions for future reference.
- Observe all warnings on the equipment and in the operating instructions.
- Follow all operating and user instructions.
- Connect the equipment to a power supply only of the type described in the operating instructions or marked on the equipment.
- The unit should be located away from power lines.
- Maximum permissible exposure (MPE) limits – This equipment complies with FCC (OET bulletin 65) general population/uncontrolled exposure limits as applied to RF energy from a Mobile device. (A mobile device being defined as a transmitting device designed to be used in other than fixed locations and to be generally used in such a way that a separation distance of at least 20 centimetres is normally maintained between the transmitter's radiating structures and the body of the user or nearby persons.)

3 REGULATORY AND TYPE APPROVAL INFORMATION

3.1 European Compliance

The equipment is designed, tested and declared to conform to the following European directives and standards:



1999/5/EC (CE mark - R&TTE) [includes directives 89/336/EEC (EMC) and 73/23/EEC (LVD)]

Relevant Standards:

EN301 489-20 v1.2.1(2002-11)

EN 60950-1:2001

ETSI EN 301 426 v1.2.1(2001-10)

ETSI EN 301 489-1 v1.4.1

EMC Testing

Electrical Safety (R&TTE)

Radio Approval

The Declaration of Conformity can be found at APPENDIX – A.

3.2 FCC Authorisation

The following information is provided on the device covered in this document in compliance with FCC regulations:

- Model number: SAT-201
- Company Name: Satamatics Ltd.
Gloucester Road
Tewkesbury
GL20 5TT
UK

Also see MPE statement in Section 2.1.

3.3 INMARSAT Type Approval

The SAT-201 has been certified for operation on the Inmarsat Network (Inmarsat Certificate Number DST002).

3.4 Limitations on intended operating environment

The SAT-201 can be used in a wide range of control and monitoring applications. When third party equipment is attached, such third party equipment and all cabling must be of suitable design and installation to ensure that the overall system complies with the requirements of the appropriate CE directives.

Guidance notes for the installation and use of the SAT-201 must be strictly followed.

Satamatics exercise due diligence to ensure that the equipment is suitable for use in stated applications, but ultimate responsibility for the compliance of a complete system must rest with the prime contractor at a site where local conditions may require additional EMC precautions be taken.



WARNING: Changes or modifications to this unit not expressly approved by the party responsible for compliance could void the user's authority to operate this equipment.

4 SAT-201 GENERAL DESCRIPTION

The SAT-201 is a compact, single unit, low data rate satellite terminal, designed to operate over the INMARSAT satellites using the INMARSAT D+ protocol. With an integral GPS receiver, the SAT-201 provides low cost satellite communications for applications such as asset tracking, telematics and SCADA exception reporting. If you do not need battery backup, solar panel power inputs or 4-20mA analogue output drivers then this is the solution for you.

Four INMARSAT satellites provide Global Coverage with each satellite covering an 'Ocean Region' (IOR, AOR-E, AOR-W or POR).

On power on or 'waking up', a terminal first tunes to the Bulletin Board channel, which contains information on the traffic channels currently in use. From the traffic channel / service ID mapping posted on the Bulletin Board, the terminal determines on which traffic channel to expect its messages, and re-tunes to this channel.

Data rate for the forward channel (to terminal) is approximately 9 user bits per second, with typical message delivery latency of about 3 minutes.

Return channel (from terminal) information is returned in bursts containing up to 80 user bits of information. The data rate is approximately 10 user bits per second, with typical message delivery latency of about 30s (assuming the terminal has already synchronised to the traffic channel).



Figure 1 – SAT-201 D+ Terminal

Mounting is via 3x M4 (No. 8) bolts or central M25 thread on base. Cable entry is from the centre base, connector details are given in section 11.

5 INSTALLATION



IMPORTANT: *Installation and service should only be carried out by suitably qualified service personnel.*

Local working practices and regulations for wiring and installations must be adhered to at all times.

5.1 Power Requirements

The equipment is powered from an external DC supply of 9.6V to 32V. The DC supply must be capable of providing a maximum VA of 9.6W, for example 1A @ 9.6V or 0.3A @ 32V.

External power is connected via the 12-way connector (see section 11 for connector details and pin connections)

When installing the SAT-201, adequate circuit protection must be provided as required by local regulations.



IMPORTANT: If connecting to an external battery, the SAT-201 requires an external fast acting fuse connected in series with the +ve supply at the battery end of the cable.

Input voltage	Fuse Rating	Minimum wire gauge
9.6 to 32 VDC	1A	24 AWG (7/0.2)



IMPORTANT: If an external AC/DC Adaptor is used to power the equipment, it must meet the requirements of EN 60950-1. The output of the Adaptor must also meet the SELV limits of EN 60950-1.

5.2 Cable

It is recommended that cable routing is planned and operation tested before committing to a permanent installation. The maximum cable diameter must not exceed 7mm.

- ❑ As standard, the SAT-201 is supplied without cable or mating connector. (See section 11 for mating connector details). Suitable cables and/or connectors can be purchased separately from your equipment supplier or authorised dealer.
- ❑ When routing the cable avoid sharp edges and pinches.
- ❑ Be aware of the minimum static bend radius of the cable.
- ❑ Mechanical pressure on the cable may cause loss of functionality or even a short circuit and subsequent damage to the terminal.
- ❑ Use only shielded cables for connecting to peripherals. Using shielded cables ensures that the appropriate EMC classifications are maintained.

5.3 Location

- ❑ The SAT-201 is only weatherproof if the interface connector is correctly mated with a Bulgin 400 series Buccaneer connector. Please consult your dealer if you are in any doubt.
- ❑ The SAT-201 should be located with an unobstructed, clear view of the sky.
- ❑ The SAT-201 should be mounted on a flat horizontal surface.
- ❑ Consider the position of the satellites. The Inmarsat satellites are in geostationary orbits above the equator. (i.e., in the Northern hemisphere the satellites are located to the South; in the Southern hemisphere the satellites are located to the North.) The further away from the Equator the SAT-201 is, the lower the degree of elevation will be above the horizon.
- ❑ If you plan to install the SAT-201 in a partially enclosed environment, test operation before committing to a permanent installation.
- ❑ On vehicles, the SAT-201 should be located on the highest point possible, free from obstructions and safe from damage during normal operation of the host vehicle.
- ❑ For installations exposed to shock and/or vibration, use a mounting scheme that isolates the unit from the excessive shock and/or vibration.
- ❑ Choose a location that is not near radar installations, other satellite communication equipment, and/or microwave dishes to prevent RF jamming.
- ❑ Avoid mounting on hot surfaces.

5.4 Mounting

- If possible, try the installation before drilling any holes or fixing cable.
- Record the ISN number of the unit for future reference.
- The SAT-201 may be mounted by utilising either the three outer M4 mounting holes (Figure 2) or the M25 thread on the base (Figure 3).
- If using the three outer mounting holes (recommended for installations exposed to shock and/or high vibration):
 - Drill a central 40mm hole to pass the connector and base mounting thread through.
 - Position the SAT-201 and mark the location of the three mounting holes.
 - Drill three 4.5mm mounting holes.
 - Secure the SAT-201 in place using M4 (No.8) screws and nuts - **Do not over tighten.**
 - Alternatively, secure using screws appropriate to the mounting surface - **Do not over tighten.**
- If using the M25 base mounting thread:
 - Drill a 26mm hole to pass the connector and mounting thread through.
 - Secure using M25 nut - **Do not over tighten.**

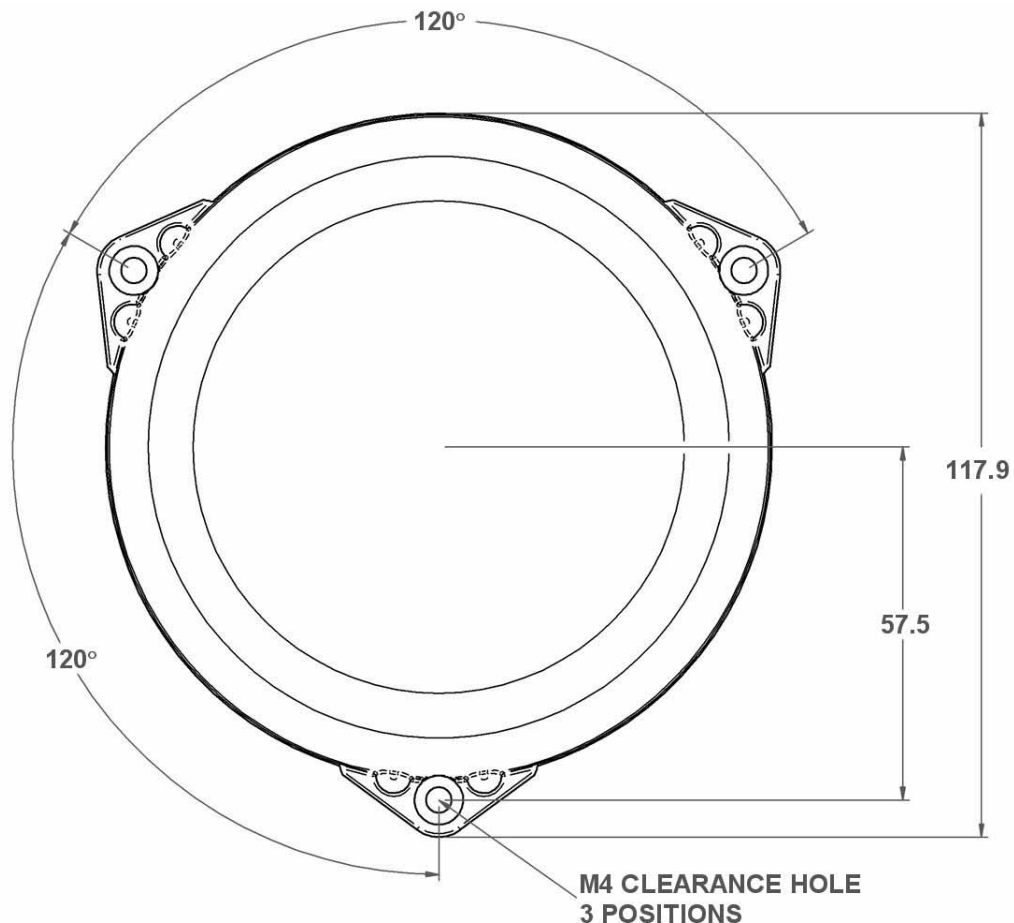

Figure 2 - SAT-201 M4 Drilling Diagram (not to scale)

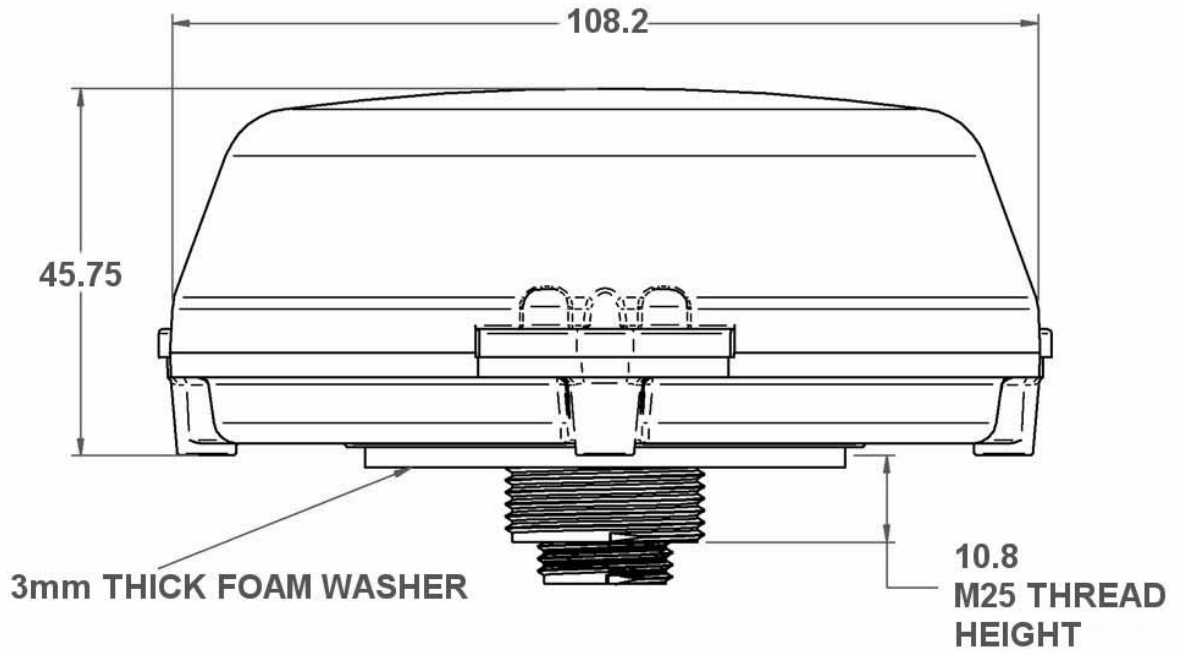

Figure 3 - SAT-201 M25 Drilling Template (not to scale)

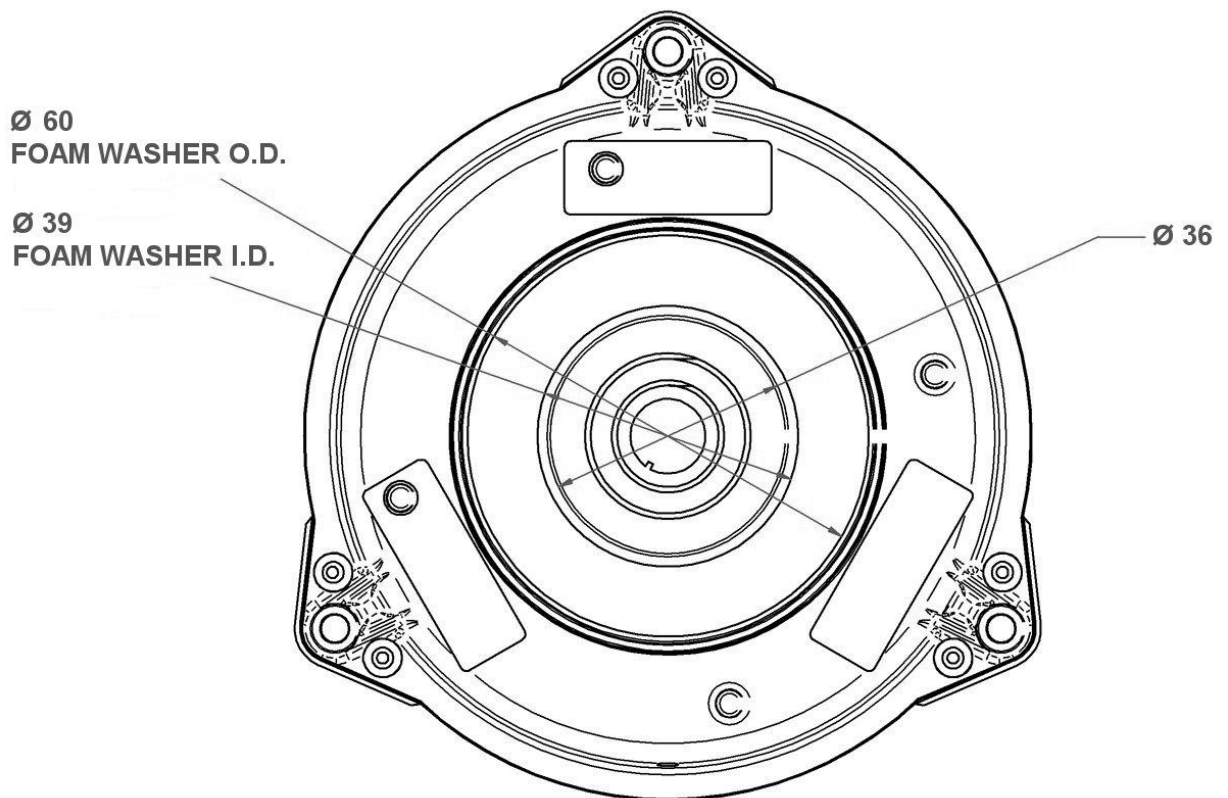

Figure 4 - SAT-201 Foam Washer Dimensions (not to scale)

5.5 Applying Power

Before connecting the SAT-201 to an external voltage source ensure that the polarity is correct and the voltage source (at the input to the SAT-201) is between 9.6V and 32V. See Section 11.1 for connector pin out description. See Section 5.1 for further details and requirements regarding the power source.

Check the circuit, in particular fuses and/or circuit protection devices.

Always ensure that the ground connection is connected before power is applied.

5.6 Operational Check

When the SAT-201 first powers up, it includes instructions to start its GPS receiver. After it has acquired its GPS position, it then identifies the best Ocean Region to use and proceeds through the sequence of states referred to in Section 12. If, for some reason, the unit is not able to obtain a valid GPS reading after two minutes, it will follow the sequence using the default Ocean Region (AORE).

If you wish to check the overall system operation, it will be necessary to ensure that the terminal is activated on a known gateway and that you have access to the application running there, so that you can view the received data. If you do not have access to an application of your own, it is possible to set up your terminal on one of the Satamatics websites in order to perform end-to-end testing. Please consult your service provider for details of the activation that has been put in place for your terminal. If you do not have access to the application, it is still possible to check the local operation of the terminal and its installation by using the following sequence. In this case it will then be necessary to check the application part of the system later.

With the SAT-201 in position, apply power to the unit and monitor the indicator. Initially it will either be off or will be in the D+ off state, and will then cycle through the following states.

RED	OFF	OFF	OFF	D+ Off
RED	OFF	GREEN	OFF	Acquiring Bulletin Board
GREEN	GREEN	RED	RED	Demodulating Bulletin Board
GREEN	ORANGE	GREEN	OFF	Acquiring Traffic Channel

Once it has acquired the traffic channel, the unit will cycle through the following two states in normal operation.

GREEN	GREEN	GREEN	OFF	Demodulating Traffic Channel
GREEN	OFF	OFF	OFF	Idle part of TC Frame

The terminal will transmit its initial report (LED turns orange for ten seconds) after successfully completing the above states. The total process to transmission will normally take between three and six minutes.

Providing that your terminal has been activated and set up within an application, the data will be available within about one minute of the actual transmission, although this is dependent on the operation of the software being used by your service provider as well as the link to the Satamatics server.

Your service provider will be able to supply you with further details regarding the normal use of the terminal, as well as scripts and forward channel use.



IMPORTANT: The foregoing only applies to terminals that are set at Factory Default and with the default script installed (see Section 8). If you are unsure about the state of your terminal, you should consult your service provider.

6 FUNCTIONALITY

For full functional details on the SAT-201 contact your authorised dealer.

7 MODES OF OPERATION

SLEEP

Extremely low power mode. D+ and GPS functions are switched off. IDLE mode is entered periodically so that external voltage can be checked.

IDLE

In certain circumstances, the terminal will enter IDLE mode. For example, where GPS is not required and the current Traffic Channel frame contains no forward messages addressed to the unit.

GPS ONLY

Similar to IDLE mode except that GPS is active, enabling the terminal to monitor its position and compare, for example, against a Geofence.

STATIC

Normal D+ operation where the terminal cycles between RECEIVE, IDLE and TRANSMIT as appropriate. GPS is not enabled.

MOBILE

Similar to STATIC mode except that GPS is also enabled.

8 FACTORY DEFAULTS

The terminal is shipped with Factory Defaults set. When power is initially applied, the script timer, alarm and operation definitions are cleared; the terminal then powers up, acquires the GPS position and tunes to the best ocean region for the terminal location. Once the terminal has acquired the D+ satellite signal it transmits a single position report burst.

9 MAINTENANCE AND SUPPORT INFORMATION

9.1 Cleaning

Dust and finger marks can be removed using a soft damp cloth. Avoid using domestic cleaning products.

9.2 Technical Support and Information

For technical support, product queries and information please contact your equipment supplier or authorised dealer.

Authorised dealers and general information about Satamatics products and services can be found at:

<http://www.satamatics.com>

10 SPECIFICATIONS

Physical

Dimensions	112mm(diam) x 45.75mm(height) (Does not include mounting threads/extensions)
Weight	350g
Colour	UN0332 (Coconut)
Connector	12 way plug. Bulgin 400 Series Buccaneer compatible

Environmental

Temperature	-40°C to +70°C
Humidity	≤ 95% @ +40°C
Vibration	5-20Hz: 1.92m ² s ⁻³ random noise 20-500Hz: -3dB octave random noise
Shock (survival)	Half sine 6ms, 300ms ⁻²
Ingress Protection Rating	IP66 (when interface connector is correctly mated)

Frequency Range

Transmit	1626.5 MHz to 1660.5 MHz
Receive	1525.0 MHz to 1559.0 MHz
GPS	1575.42 ± 1.0 MHz

<u>Elevation Angle Range</u>	0° to 90°
-------------------------------------	-----------

Transmitter

EIRP	0 - 9dBW
Modulation	2 level FSK, 256Hz tone spacing
Tx burst duration	8s (Global Beam)
User data rate	~10 bits per second (Global beam)
Message length	Up to 84 bits per burst

Receiver

G/T	≥ -25dB/K at EL = 30°
Modulation	32-ary FSK, 20Hz tone spacing
User data rate	~9 bits per second
Message length	Up to 1000 bits

GPS

Channels	12
Time To First Fix (Typical)	
Cold start	45s
Hot start	<8s (GPS was off for less than 2 hours)
Accuracy (SA Off)	
Position (CEP, 2D)	4m (Typical)
Altitude	maximum 18000m
Dynamic capability	
Velocity	maximum 515m/s
Acceleration	≤4g
Maximum update rate	1s

SAT-201 User Manual

GPS test interface (not available during normal operation)

Interface	Asynchronous serial RS232
Baud rate	38400 bps
Parity/data bits/stop bits	N,8,1

Control & Monitoring

Interface	Asynchronous serial RS232
Baud rate	9600 bps
Parity/data bits/stop bits	N,8,1

Data Interfaces

2 x Inputs	Individually configurable as: <ul style="list-style-type: none">○ Digital input (32V maximum)○ Switch input (internal pull up used with external switch to ground)○ SAT-101 compatible I/O (low voltage)○ Analog input (12 bit ADC, 0 to 2.5V)
2 x Outputs	Open drain output (250mA max sink current)

Power Consumption (Typical@12V)

Sleep	0.5mW
Receive (incl. GPS)	1.5W
Transmit	6W

<u>Power Supply Voltage</u>	9.6V to 32V 'smoothed' DC
------------------------------------	---------------------------

11 INTERFACES

The interface connector is a 12 way plug that mates with a Bulgin Buccaneer 400 series socket. Bulgin part numbers for the mating connector are:

1. Connector: PX0410/12S/6570
2. Solder contacts: SA3179/1 (pack of 10)
3. Crimp contacts: SA3179 (pack of 10). Contact Bulgin for crimp tool details
4. Insertion/extraction tool: 13027

Items 1,2 & 4 can be purchased as a kit from your equipment supplier or authorised dealer (Satamatics part number: 00925)

11.1 Interface Connector Pinout

The connector has the following pin connections:

Pin	Function	Cable colour code (if supplied by Satamatics)
1	0V (cable screen)	[Screen]
2	Voltage In (VIN+)	Red
3	0V (VIN-)	Orange
4	OUT2	Yellow
5	OUT1	Green
6	IN2	Blue
7	IN1	Purple
8	Rx	Grey
9	Tx	White
10	0V (VIN-)	Black
11	Rx GPS	Brown
12	Tx GPS	Pink

11.2 Interface functions

VIN+, VIN-	External power input – 9.6V to 32V
Tx, Rx	RS232 serial control/data interface transmit (Tx) and receive (Rx) lines <ul style="list-style-type: none"> o 9600bps, asynchronous, optional parity o Control function – for configuring the unit o Data function – for message input/output
Tx GPS, Rx GPS	RS232 serial GPS test interface transmit (Tx) and receive (Rx) lines. 38400bps, asynchronous, optional parity. Used for software download. Not available during normal operation.
IN _n	2 off inputs individually configurable as: <ul style="list-style-type: none"> o Digital input (32V maximum) with falling edge interrupt capability o Switch input (internal pull up used with external switch to ground) with falling edge interrupt capability o SAT-101 compatible digital input (low voltage) with falling edge interrupt capability o Analog input (12 bit ADC, 0 to 2.5V) o SAT-101 compatible digital output (low voltage)
OUT _n	2 off digital open drain outputs (250mA max sink current) suitable for driving relays, indicators etc.

11.3 General Purpose I/O

Figure 5 shows a conceptual drawing of one of the general purpose inputs (INs).

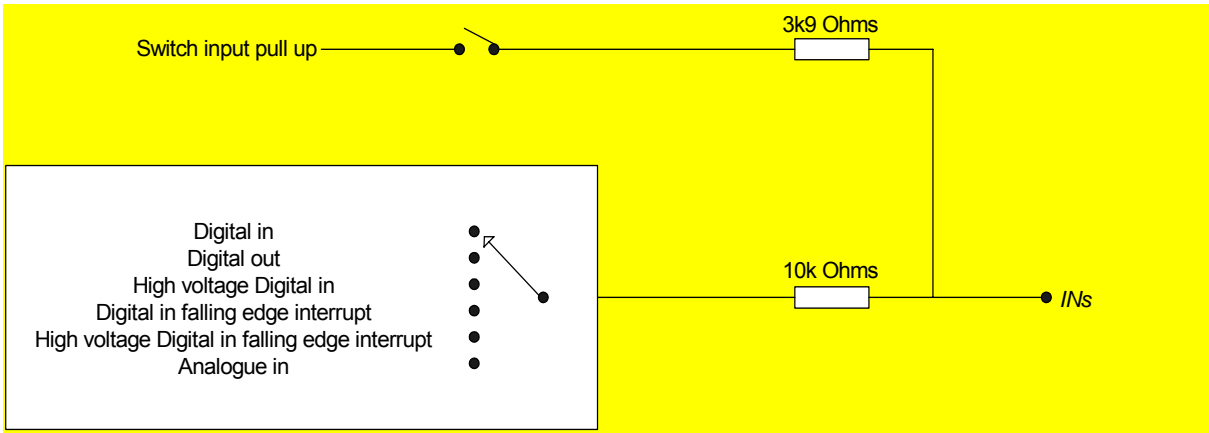

Figure 5 SAT-201 general purpose Input block diagram

Figure 6 shows a conceptual drawing of one of the general purpose Outputs (OUTs).

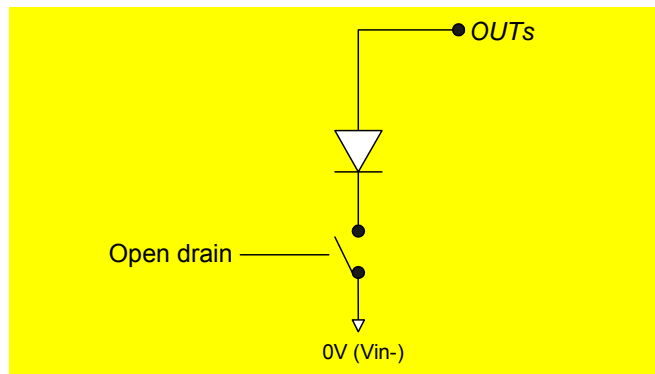

Figure 6 SAT-201 output block diagram



IMPORTANT: The factory default configuration disables the SAT-201 outputs OUT1 and OUT2. To use these outputs the user must ensure that they are configured as open drain outputs. Failure to do so will cause unexpected results.

12 INTERPRETING THE INDICATOR

A single status indicator is provided on the SAT-201. The indicator goes through 4 states every 2 seconds generating the patterns in the table below

State 1	State 2	State 3	State 4	Meaning
RED	RED	RED	RED	Fault
RED	OFF	OFF	OFF	D+ OFF
RED	OFF	GREEN	OFF	Acquiring Bulletin Board
GREEN	GREEN	RED	RED	Demodulating Bulletin Board
GREEN	ORANGE	GREEN	OFF	Acquiring Traffic Channel
GREEN	GREEN	GREEN	OFF	Demodulating Traffic Channel
GREEN	OFF	OFF	OFF	Idle part of TC Frame
ORANGE	ORANGE	ORANGE	ORANGE	Transmitting
GREEN	RED	ORANGE	OFF	Software download in progress

Normally, from power on, the indicator will go from flashing red (D+ OFF) through to flashing green as the SAT-201 first acquires the Bulletin Board and subsequently the Traffic Channel. From power on to demodulating the Traffic Channel may take up to 7 minutes.

NOTE: *The indicator can be disabled (off state) or enabled via script control. The indicator may therefore not come on when power is applied. Contact your authorised dealer for details of any script that may have been programmed into the SAT-201.*

13 APPENDIX – A

13.1 CE Declaration of Conformity

Declaration of Conformity

<p><u>Manufacturer</u></p> <p>SATAMATICS Ltd. Gloucester Road, Tewkesbury, Glos. GL20 5TT UK</p>			
<p><u>Product Identification</u></p> <p>Product description: Inmarsat D+ Mobile Earth Terminal (MET) Model number: SAT-201</p> <p>The product is in conformity with the following directives (<i>and associated amending directives</i>) based on test results using harmonised standards:</p> <ul style="list-style-type: none"> • R&TTE Directive 1999/5/EC, including: <ul style="list-style-type: none"> ○ Low Voltage Directive 73/23/EEC ○ EMC directive 89/336/EEC • Automotive Directive 95/54/EC 			
<p><u>Harmonised Standards Used</u></p> <p>Radio standards per Article 3.2.: ETSI EN 301 426 v1.2.1</p> <p>EMC standards per Article 3.1b): ETSI EN 301 489-20 v1.2.1 ETSI EN 301 489-1 v1.4.1</p> <p>Safety standards per Article 3.1a): EN 60950-1:2001</p>			
<p><u>Additional Information</u></p> <table border="1" style="width: 100%;"> <tr> <td style="width: 50%;"> <p>Technical file held by:</p> </td> <td style="width: 50%;"> <p>SATAMATICS Ltd. Gloucester Road, Tewkesbury, Glos. GL20 5TT UK</p> </td> </tr> </table> <p>We, SATAMATICS, hereby declare under our sole responsibility that the equipment identified above complies with all the essential requirements of the directives.</p>		<p>Technical file held by:</p>	<p>SATAMATICS Ltd. Gloucester Road, Tewkesbury, Glos. GL20 5TT UK</p>
<p>Technical file held by:</p>	<p>SATAMATICS Ltd. Gloucester Road, Tewkesbury, Glos. GL20 5TT UK</p>		

Signed:



Title: J Hatherall, Engineering Director , Satamatics Ltd.

14 PRODUCT INFORMATION

It is essential that the following information be completed at the time of installation/purchase to ensure that any future warranty claims are dealt with as expeditiously as possible.

DATE OF PURCHASE:

PURCHASED FROM:

SAT 201 ISN:

D	S	T	0	0	2									
---	---	---	---	---	---	--	--	--	--	--	--	--	--	--

SAT 201 SERIAL NUMBER:

IMPORTANT: PLEASE KEEP IN A SAFE PLACE FOR FUTURE REFERENCE

NOTES:

Dealer:

Satamatics Ltd

Corporate Head Office

Tel: +44 (0)1684 278610

Fax: +44 (0)1684 278611

info@satamatics.com

www.satamatics.com

Satamatics USA

Tel: +1 877 SAT MATD

Tel: +1 877 728 6283

info@satamaticsUSA.com

www.satamaticsUSA.com